

PORTABLE AUTOMATIC ICE MAKER

User Manual

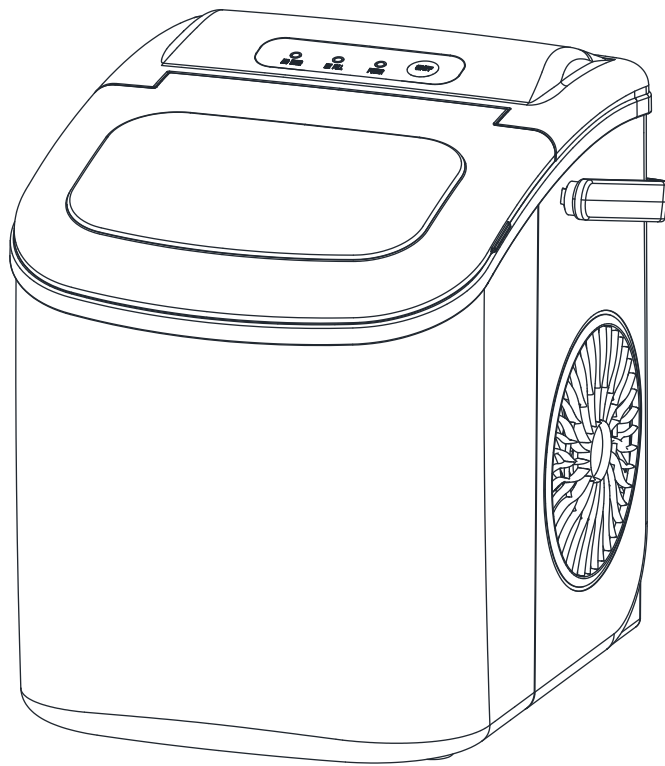

HZB-12/H

TABLE OF CONTENTS

IMPORTANT SAFETY INSTRUCTIONS	2
PREPARING YOUR ICE MAKER FOR USE	
IMPORTANT SAFETY TIPS.....	3
PACKING LIST	4
GETTING TO KNOW YOUR UNIT	5
AUTOMATIC SELF-CLEANING PROGRAM	5
OPERATING PROCEDURES & MAINTENANCE	
UNPACKING YOUR ICE MAKER.....	7
ASSEMBLE HANDLE	7
CONNECTING YOUR ICE MAKER.....	8
CLEANING AND MAINTAINING YOUR ICE MAKER.....	8
USING YOUR ICE MAKER	9
TROUBLESHOOTING.....	9
TECHNICAL PARAMETERS & CIRCUIT DIAGRAM	10
EXPLOSIVE DRAWINGS	11

IMPORTANT SAFETY INSTRUCTIONS

Your safety and the safety of others are very important.

We have provided many important safety messages in this manual and on your appliance.

Always read and obey all safety messages.

This is the safety alert symbol:



All safety messages will follow the safety alert symbol and the word “DANGER” or “WARNING”.

 **DANGER**

 **WARNING**

These words mean:

Death or serious injury may occur if you don't immediately follow instructions.

All safety messages will tell you what the potential hazard is, how to reduce the chance of injury, and what can happen if the instructions are not followed.

PREPARING YOUR ICE MAKER FOR USE

IMPORTANT SAFETY TIPS

When using electrical appliances, basic safety precautions should be followed to reduce the risk of fire, electric shock, and injury to persons or property. Read all instructions before using any appliances .

- Do not operate this ice maker, or any other appliance with a damaged cord. If the supply cord is damaged, it must be replaced by the manufacturer, its service agent or a similarly qualified person in order to avoid a hazard. This ice maker must be positioned where the plug is accessible. Connect to properly polarized outlets only. No other appliance should be plugged into the same outlet. Be sure that the plug is fully inserted into the socket.
- Do not run the power cord over carpeting or other heat insulators. Do not cover the cord. Keep the cord away from traffic areas and do not submerge it in water.
- We do not recommend the use of an extension cord, as it may overheat and become a risk of fire. If you must use an extension cord, the cord must be of No.14AWG minimum size with its rated watts no less than 1875W.
- Unplug the ice maker before cleaning or making any repairs or servicing.
- Exercise caution and use reasonable supervision when the appliance is used near children.
- Do not use your ice maker outdoors. Place the ice maker away from direct sunlight and make sure that there is at least 4 inches of clearance between the back of your unit and wall. The minimum clearance from each side of the unit must be no less than 4 inches.
- Do not use liquids other than water to make the ice cube.
- Do not clean your ice maker with flammable fluids. The fumes can create a fire hazard or explosion.
- Do not tip it over.
- If the ice maker is brought in from outside in wintertime, give it a few hours to warm up to room temperature before plugging it in.

WARNING: This appliance must be earthed.

- **DANGER – Risk Of Fire or Explosion. Flammable Refrigerant Used. Do Not Use Mechanical Devices To Defrost Ice Maker. Do Not Puncture Refrigerant Tubing.**



- **DANGER – Risk Of Fire Or Explosion. Flammable Refrigerant Used. To Be Repaired Only By Trained Service Personnel. Do Not Puncture Refrigerant Tubing.**

- CAUTION – Risk Of Fire Or Explosion. Flammable Refrigerant Used. Consult Repair Manual/Owner’s Guide Before Attempting To Install or Service This Product. All Safety Precautions Must be Followed.
- CAUTION – Risk Of Fire Or Explosion. Disposal Of Property In Accordance With Federal Or Local Regulations. Flammable Refrigerant Used .
- CAUTION – Risk Of Fire Or Explosion Due To Puncture Of Refrigerant Tubing;Follow Handling Instructions Carefully. Flammable Refrigerant Used.
- The ice maker should be installed in accordance with the safety standard for Refrigeration Systems, ASHRAE15. The ice maker shall not be installed in corridors or hallways of public buildings.
- If problems that need servicing occur, such as the replacement of some components, the servicing shall be done by service personnel authorized by the factory to minimize the risk of possible ignition due to incorrect components or improper service.

IMPORTANT:

The wires in this main lead are colored in accordance with the following code:

Green or Green with a yellow strip:	Grounding
White:	Neutral
Black:	Live

To avoid a hazard due to instability of the appliance, it must be placed on an even and flat surface.

PACKING LIST

No.	Description	Quantity
1	Manual	1 pc
2	Ice Basket	1 pc
3	Ice Scoop	1 pc
4	Handle	1 pc

GETTING TO KNOW YOUR UNIT

General instruction

1. Ice scoop
2. Ice full sensor
3. Ice basket
4. Top cover with transparent window
5. Air exhausting
6. Water drain cap: at the front bottom side of the unit.
7. MAXIMUM WATER LEVEL: ——— ▲ ———

Remove the ice basket, and you can see the water level mark.

8. Handle.

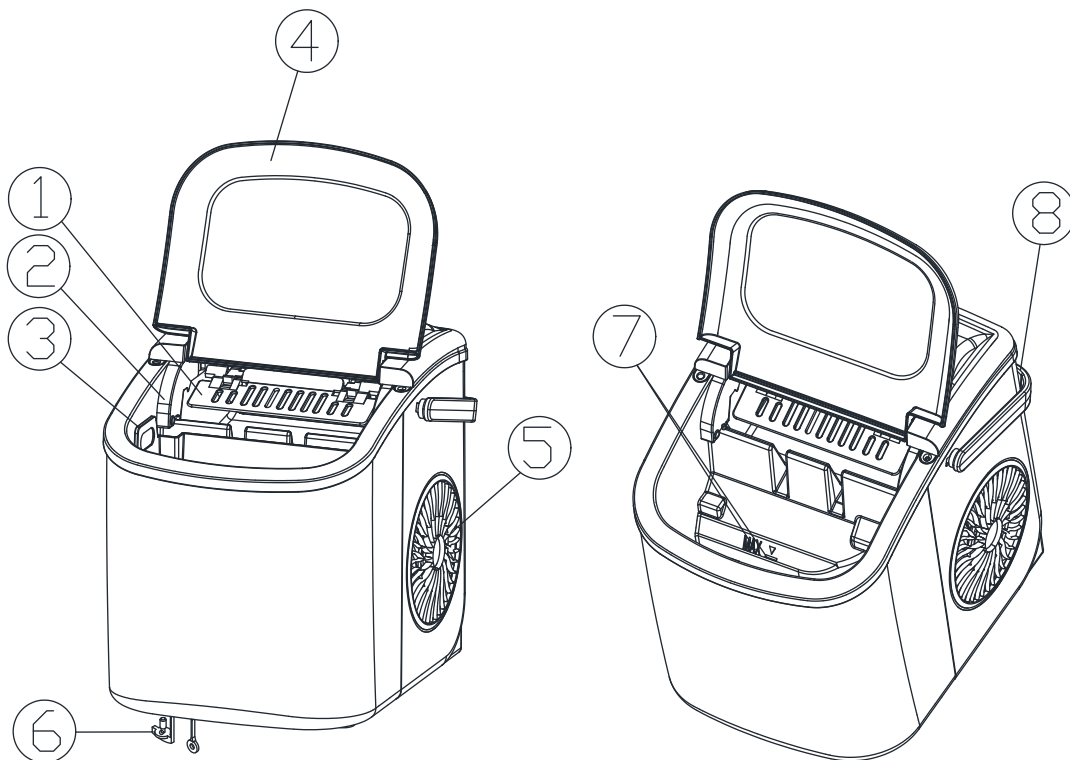

AUTOMATIC SELF-CLEANING PROGRAM

Plug in the unit and press "ON/OFF" button on the control panel for more than 5 seconds. It takes 30 minutes to enter the self-cleaning program. The "Ice Full, Add Water" indicator flashes during the cleaning. After cleaning, drain the water from the inner tank through the drainage outlet at the bottom of the machine.

OPERATING PROCEDURES & MAINTENANCE

Position of control panel & function

Control Panel: easy to use, visible function setting on touch display.

- A. Button to turn on/off the unit.
- B. Power indicator
- C. Ice Full indicator
- D. Water shortage indicator

CONTROL
PANEL

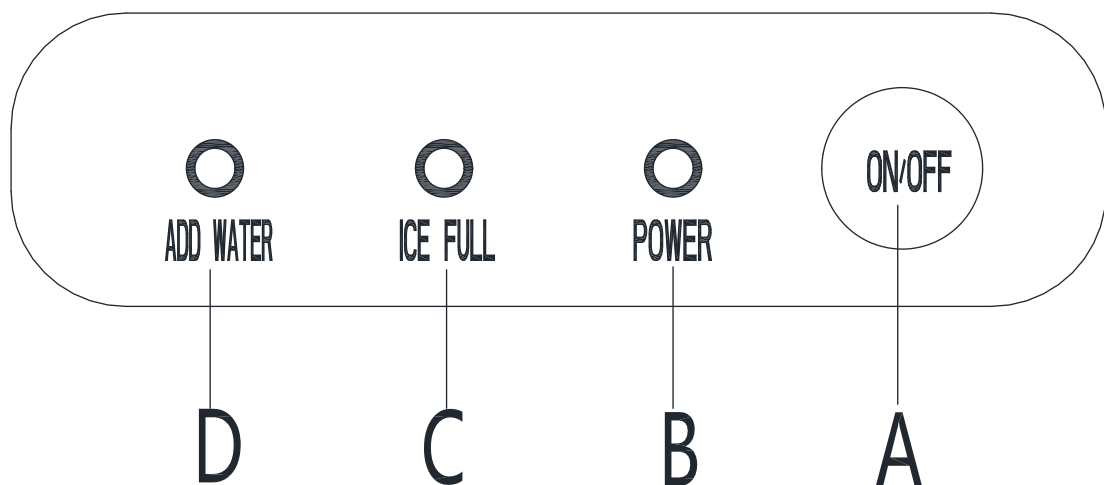
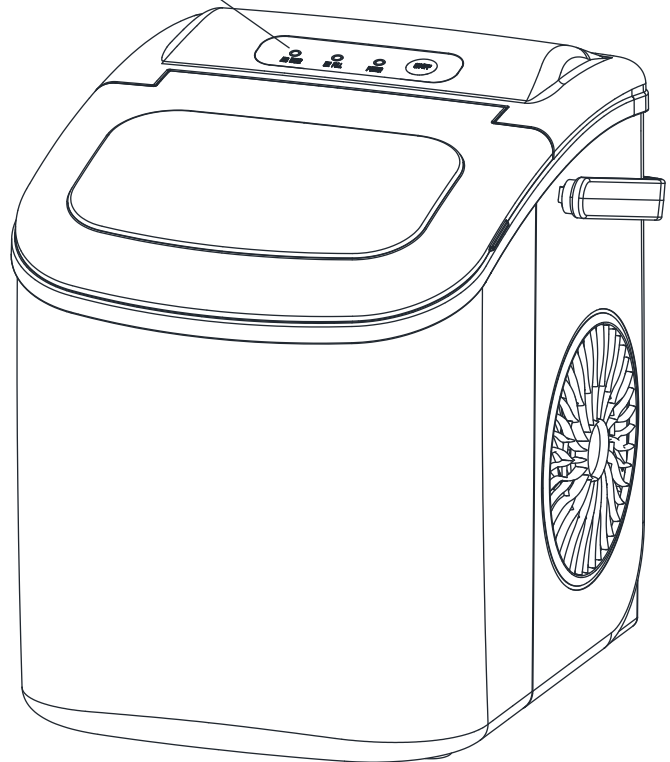

UNPACKING YOUR ICE MAKER

1. Remove the exterior and interior packaging. Check if the ice basket and the ice scoop are included. If any parts are missing, please contact our customer service.
2. Remove the tapes used to fix the ice shovel, ice basket and ice scoop. Clean the tank and the ice basket.
3. Put the ice maker on a level and flat counter top away from direct sunlight and other sources of heat (i.e.: stove, furnace, radiator). Make sure that the minimum clearance between the wall and the back, left, and right sides of the unit should be at least 4 inches.
4. Allow one hour for the refrigerant fluid to settle before plugging in the ice maker.
5. The appliance must be positioned where the plug is accessible.

WARNING: Fill with drinking water (potable water) only.

ASSEMBLE HANDLE

Rotate the handle to the same angle as the mounting hole on the machine. Make sure the handle is inserted into the machine.

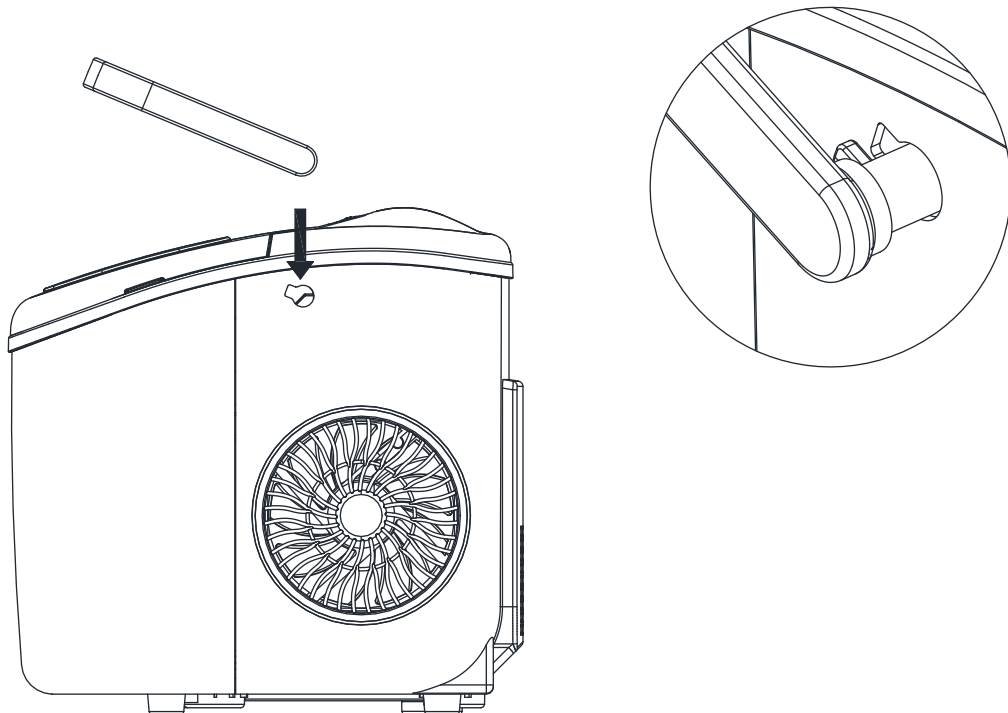

CONNECTING YOUR ICE MAKER



DANGER

*** Improper use of the grounding plug can result in the risk of electrical shock. If the power cord is damaged, please call our customer service.**

1. This unit should be properly grounded for your safety. The power cord of this appliance is equipped with a three-prong plug which matches with standard three-prong wall outlets to minimize the possibility of electric shock.
2. Plug your appliance into a specialized grounding wall outlet that is properly installed. Do not, under any circumstances, cut or remove the third (grounding) prong from the power cord. Any questions concerning power and/or grounding should be directed toward a certified electrician.
3. This appliance requires a standard 110-120 volt, 60Hz electrical three-prong grounding outlet.

CLEANING AND MAINTAINING YOUR ICE MAKER

Before using your ice maker, it is strongly recommended to clean it thoroughly.

1. Take out the ice basket.
2. Clean the interior with diluted detergent, warm water and a soft cloth.
3. Then rinse the inner parts with water and drain out the water by unplugging the drain cap on the front bottom side.
4. The outside of the ice maker should be cleaned regularly with a mild detergent solution and warm water.
5. Dry the interior and exterior with a clean soft cloth.
6. When the machine is not in use for a long time, drain the water completely out and dry the interior.

USING YOUR ICE MAKER

1. Open the cover, remove the ice basket and pour water into the tank.
Keep the water level below the max water level mark.
2. Press “ON/OFF” button on the control panel to begin the ice-making cycle.
3. Ice-making cycle lasts approximately 6 to 13 minutes, which depends on the selection of ice cube size and the room temperature. The recommended room temperature is 50°F to 105°F.
4. If the water pump can't inject water, the ice maker will stop automatically and the “ADD WATER” indicator will be on. Press “ON/OFF” button, add water to the max water level mark, and press “ON/OFF” button to turn on the unit again. Allow at least 3 minutes for the refrigerant liquid inside the compressor to settle before restarting.
5. The ice maker stops when the ice basket is full and the “ICE FULL” indicator will be on.
Warning: Direct sunlight or sunlight reflection may cause infrared sensor malfunction. If the unit doesn't stop even when ice cubes obstruct the sensor, move the unit to where there is no sunlight.
6. Change water in the water reservoir every 24 hours to ensure a reasonable hygienic level.
If the unit isn't to be used, drain all the water and dry the tank.

TROUBLESHOOTING

PROBLEM	POSSIBLE CAUSE	SOLUTION
“ADD WATER” indicator is on.	Lack of Water.	Stop the ice maker, add water, and press “ON/OFF” button again to restart the unit.
“ICE FULL” indicator is on.	Ice is full in basket.	Remove ice cubes from the ice basket. Continuously press “on/off” button for 5 seconds and the unit could make ice for 10 cycles even when the “Ice” indicator is on.
Ice cubes stick together.	The ice-making cycle is too long.	Stop the ice maker and restart it after the ice melts. Select ice cubes of a smaller size.
	The water temperature in the inner tank is too low.	Change the water. The recommended water temperature is 40°F - 90°F
The ice-making cycle is normal but no ice cube is formed.	The room temperature or the water temperature in the inner tank is too high.	The room temperature should be 50°F - 105°F and the water temperature should be 40°F - 90°F
	The refrigerant in the cooling system leaks.	Verify it by a qualified technician.
	The pipe in the cooling system is blocked.	Verify it by a qualified technician.

TECHNICAL PARAMETERS & CIRCUIT DIAGRAM

Model	HZB-12/H
Protection Type	I
Power	115V/60Hz
Ice Making Current	1.5A
Ice Collecting Current	1.8A
Refrigerant	R600a 0.74Oz/21g
Design Pressure	
High Side	290Psig
Low Side	88Psig
Vesicant	C ₅ H ₁₀
Net Weight	6.2Kg
Dimension (W * D *H)	222x294x290mm
Enclosure	Plastic

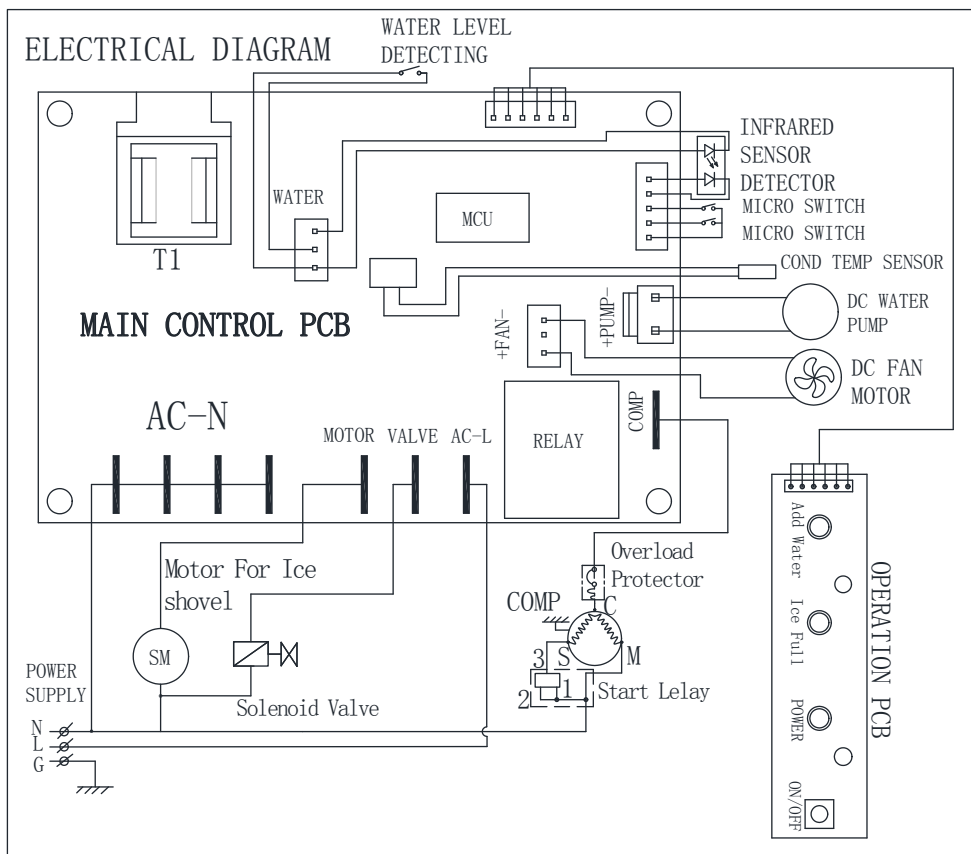

EXPLOSIVE DRAWINGS

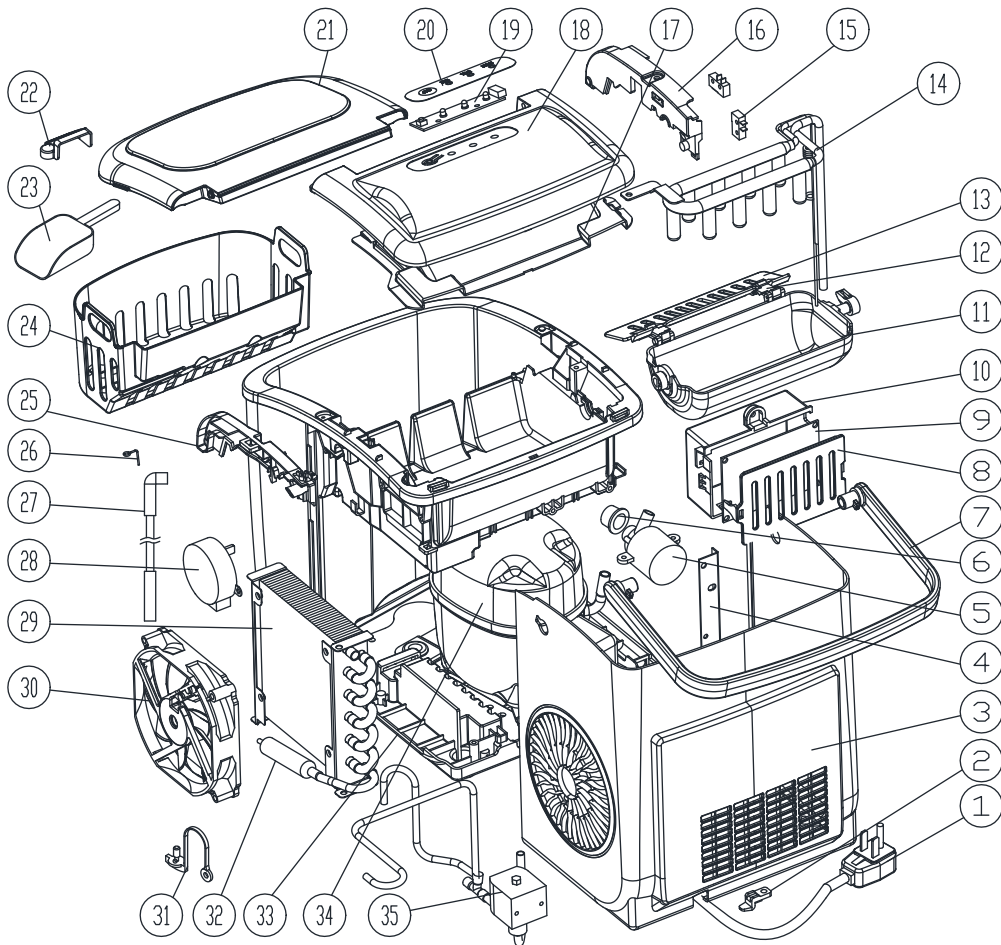

S/N	Part description	Qty/ Per	S/N	Part description	Qty /Per	S/N	Part description	Qty/ Per
1	Power cord	1	13	Ice shovel	1	25	Inner tank bracket, RH	1
2	Plastic clip	1	14	Evaporator	1	26	Stainless wire	1
3	Back panel	1	15	Micro switch	2	27	Water supply pipe	1
4	Plate back support	1	16	Inner tank bracket, LH	1	28	Synchronous motor	1
5	DC water pump	1	17	Back bottom panel	1	29	Condenser	1
6	Silicon pump sealing	1	18	Back top panel	1	30	DC fan motor	1
7	Handle	1	19	Displaying PCB	1	31	Nylon plug drain	1
8	Control box cover	1	20	Touch pad	1	32	Copper tube filter	1
9	Main PCB	1	21	Front top panel	1	33	Plastic bottom	1
10	Control box	1	22	Water filter	1	34	Compressor	1
11	Ice making box	1	23	Ice scoop	1	35	Magnetism valve	1
12	Ice scoop link	2	24	Ice basket	1	36	Internal wire	1

Thank you for purchasing this product! If you have any questions about the product, such as missing parts, damaged products, product assembling, and operation, please contact us via **Amazon Message** or customer service number: **213-4467172 or 661-4358826**

IMPORTANT

Please call our customer service department for any consulting:

213-4467172

661-4358826

(8:30am - 5:30pm P.S.T.)

DATED PROOF OF PURCHASE IS REQUIRED FOR WARRANTY SERVICE.

AVIS

Veillez appeler le service à la clientèle pour toutes questions au:

213-4467172

661-4358826

(8:30am - 5:30pm P.S.T.)

PREUVE D'ACHAT ORIGINALE REQUISE POUR SERVICE DE GARANTIE.

IMPORTANTE

Sólo hay que llamar nuestro departamento de servicio

al cliente en caso de tener preguntas o inquietudes:

213-4467172

661-4358826

(8:30am - 5:30pm P.S.T.)

SE REQUIERE PRUEBA DE COMPRA CON FECHA PARA SERVICIO BAJO GARANTÍA.

Address : 9733 Topanga Canyon Blvd. APT310, Chatsworth, CA 91311

Phone: 213-4467172 or 661-4358826